



BOARD OF STUDIES  
NEW SOUTH WALES

**2000  
SCHOOL  
CERTIFICATE  
TEST**

**7 November**

**MATHEMATICS**

**SECTION 2**

**Part B**

**25 marks**

**CENTRE NUMBER**

--	--	--	--	--

**STUDENT NUMBER**

--	--	--	--	--	--	--	--	--	--

**Directions for Section 2 Part B**

- 1 Allow about 30 minutes to answer this part
- 2 Part B Questions 76–84
- 3 Calculators may be used in Section 2
- 4 Write your answers to Questions 76–84 in this booklet
- 5 Complete your answers in either blue or black pen
- 6 Write your Centre Number and Student Number at the top of this page

Questions 76 to 80 are worth 1 mark each. Each question MAY have MORE THAN ONE correct answer. Fill in the response oval(s) completely.

---

**Question 76**

To evaluate  $\frac{(26 + 75) \times 13}{2}$  with a calculator, we could press buttons in the order

(A)  $26 + 75 \times 13 \div 2 =$

(B)  $26 + 75 \div 2 \times 13 =$

(C)  $26 + 75 = \times 13 \div 2 =$

(D)  $26 + 75 = \div 2 \times 13 =$

(A)

(B)

(C)

(D)

---

**Question 77**

'Half of a number is decreased by 5 and the result is 15.'

If the number is  $x$ , this statement could be written as

(A)  $\frac{1}{2}x - 5 = 15.$

(B)  $\frac{1}{2x} - 5 = 15.$

(C)  $\frac{x}{2} - 5 = 15.$

(D)  $\frac{1}{2}(x - 5) = 15.$

(A)

(B)

(C)

(D)

---

**Question 78**

Paulene is shorter than Mona. Ruth is taller than Stamo.

In order of increasing height, they could be

- (A) Ruth, Mona, Stamo, Paulene.
- (B) Stamo, Paulene, Ruth, Mona.
- (C) Paulene, Stamo, Mona, Ruth.
- (D) Stamo, Ruth, Paulene, Mona.

(A)                       (B)                       (C)                       (D)

---

**Question 79**

All edges of a rectangular prism are measured in whole centimetres.

One edge is 10 cm long.

The volume of the prism is  $60 \text{ cm}^3$ .

What could be the area of a cross-section of the prism?

- (A)  $10 \text{ cm}^2$                       (B)  $24 \text{ cm}^2$                       (C)  $30 \text{ cm}^2$                       (D)  $36 \text{ cm}^2$

(A)                       (B)                       (C)                       (D)

---

**Question 80**

A bag contains 64 marbles of different colours.

It is known that there are exactly 32 red marbles and exactly 12 yellow marbles.

A person draws out one marble from the bag.

Which of the following statements could possibly be true?

- (A) The probability of choosing a blue marble is 1.
- (B) The probability of choosing a blue marble is  $\frac{20}{64}$ .
- (C) The probability of choosing a blue marble equals the probability of choosing a red marble.
- (D) The probability of choosing a blue marble equals the probability of choosing a yellow marble.

(A)                       (B)                       (C)                       (D)

---

**End of questions in Section 2 Part B that may require you to fill in more than one correct answer.**

**Please turn over**

**Question 81** (5 marks)

The shaded section of this diagram is to be cut to complete the net of a solid.

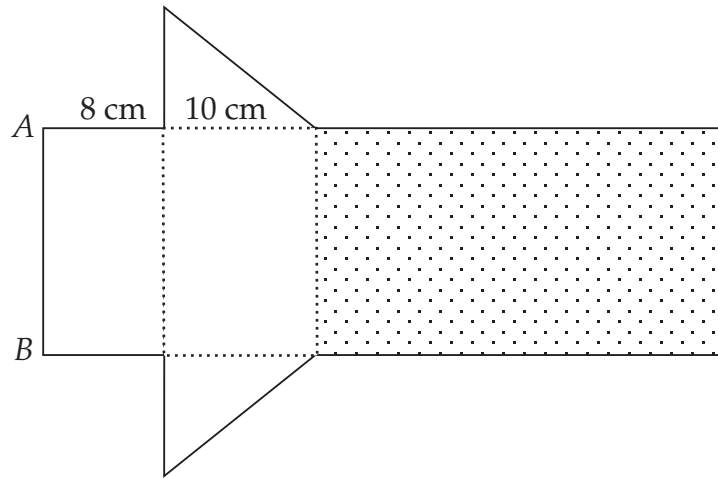

DIAGRAM  
TO  
SCALE

(a) Mark accurately where the shaded section must be cut.

(b) Name the solid that can be formed.

.....  
 .....

(c) By measurement and calculation, find the length of side  $AB$ .

.....  
 .....

(d) When assembled, the net folds into a drink container.  
 David has 12 litres of juice.

How many of these containers can he fill? (1 litre =  $1000 \text{ cm}^3$ )

.....  
 .....

**Question 82** (5 marks)

MILLENNIUM MOVIE STUDIOS

<b>Tour Prices</b>	
Adults	\$39
Children (Under 13 years)	\$28
Students (Ages 13–18 years)	\$33
Pensioners	\$27
Family ticket (2 adults, 2 children)	\$115

- (a) (i) Two adults and two children (ages 6 and 10) buy a family ticket.

How much do they save on the normal price?

.....  
 .....

- (ii) Calculate this saving as a percentage of the normal price. Write your answer to one decimal place.

.....  
 .....

- (b) A school is given a quote of \$795 for a group of 30 Year 10 students to visit the studios.

How much will each student save on the normal price?

.....  
 .....

- (c) Two people visit the studios and pay \$61 for their tickets.

What could their ages be?

.....

- (d) When the Goods and Services Tax (GST) is added, tour prices increase by 10%.

What is the new price for a pensioner?

.....

Question 83 (5 marks)

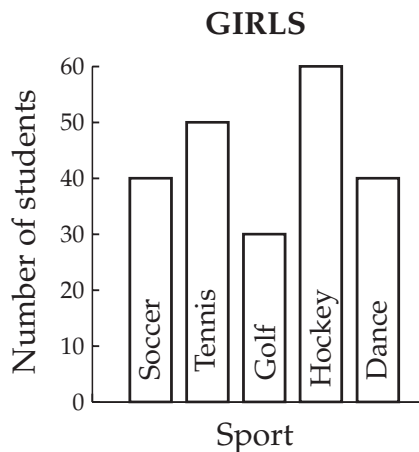
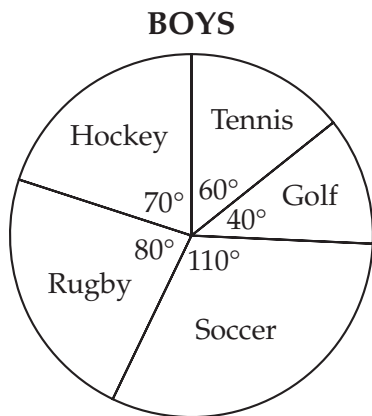

The two graphs represent sport choices at Crisela High School.

- (a) Name the two sport choices that make up exactly 50% of the boys' choices.
- .....
- .....
- (b) A boy is chosen at random. What is the probability that he plays either golf or hockey?
- .....
- .....
- (c) If there are 180 boys, how many students attend Crisela High School?
- .....
- .....
- (d) By referring to the graphs, complete the statement below.
- Tennis is a more popular sport with ..... than .....
- boys/girls                      boys/girls
- (e) Twenty new boys enrolled at Crisela High School. They chose rugby as their sport.
- What would be the new angle for rugby in the sector graph?
- .....
- .....
- .....
- .....
- .....

**Question 84** (5 marks)

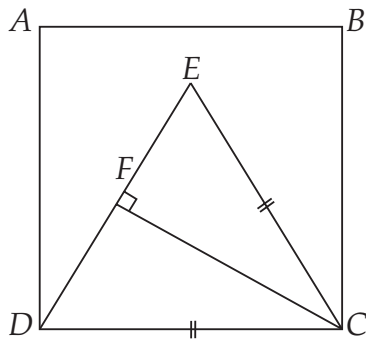

NOT TO SCALE

$ABCD$  is a square.

$\triangle DEC$  is an equilateral triangle.

Side  $EC = 6$  cm.

$CF \perp DE$ .

$F$  is the midpoint of  $DE$ .

- (a) Calculate the area of the square  $ABCD$ .

.....

- (b) Use Pythagoras' theorem to show that  $FC = 5.2$  (to 1 decimal place).

.....  
 .....  
 .....

- (c) The line  $GE$  is added to the diagram so that  $GE \perp AB$ .

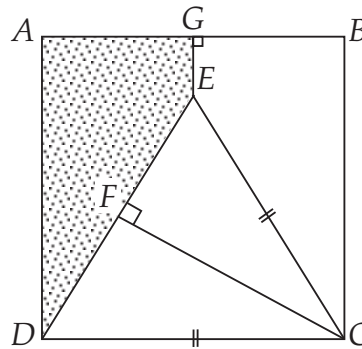

NOT TO SCALE

- (i) Find the length of  $GE$ .

.....  
 .....

- (ii) Calculate the shaded area.

.....  
 .....  
 .....

**End of test**

BLANK PAGE