

B O A R D O F S T U D I E S
NEW SOUTH WALES

2008

**HIGHER SCHOOL CERTIFICATE
EXAMINATION**

General Mathematics

General Instructions

- Reading time – 5 minutes
- Working time – $2\frac{1}{2}$ hours
- Write using black or blue pen
- Calculators may be used
- A formulae sheet is provided at the back of this paper

Total marks – 100

Section I Pages 2–11

22 marks

- Attempt Questions 1–22
- Allow about 30 minutes for this section

Section II Pages 12–21

78 marks

- Attempt Questions 23–28
- Allow about 2 hours for this section

Section I

22 marks

Attempt Questions 1–22

Allow about 30 minutes for this section

Use the multiple-choice answer sheet for Questions 1–22.

1 Which expression is equivalent to $12k^3 \div 4k$?

(A) $3k^2$

(B) $3k^3$

(C) $8k^2$

(D) $8k^3$

2 What is the surface area of the open box?

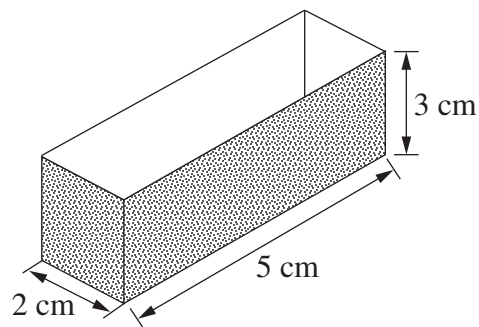

NOT TO
SCALE

(A) 10 cm^2

(B) 30 cm^2

(C) 52 cm^2

(D) 62 cm^2

3 The stem-and-leaf plot represents the daily sales of soft drink from a vending machine.

If the range of sales is 43, what is the value of (N) ?

2	(N)	5	5	
3	4	7	7	9
4	0	5	8	
5	2			
6	0	7		

- (A) 4
- (B) 5
- (C) 24
- (D) 25

4 Which graph best represents $y = 3^x$?

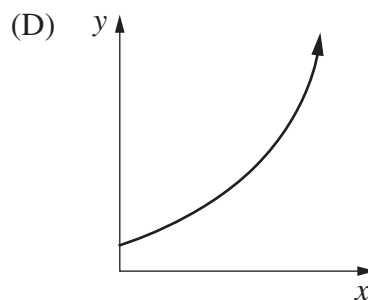
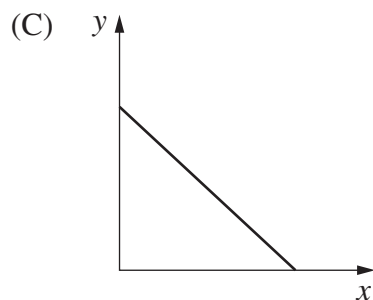
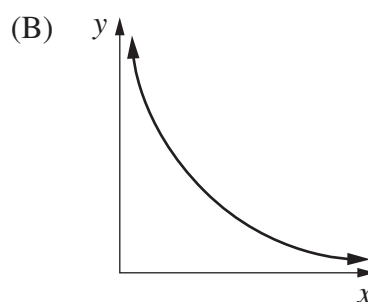
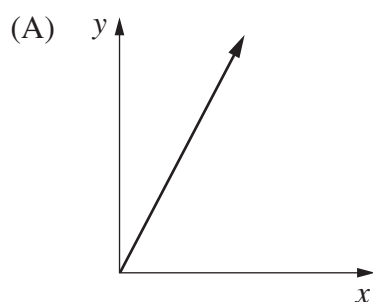

- 5 What is the size of the smallest angle in this triangle?

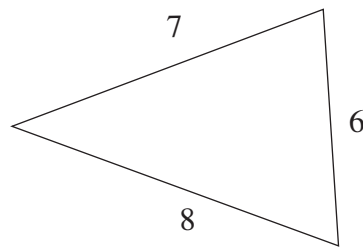

NOT
TO
SCALE

- (A) 29°
(B) 47°
(C) 58°
(D) 76°

6

<i>Taxable income</i>	<i>Tax payable</i>
\$0 – \$12 000	Nil
\$12 001 – \$30 000	Nil plus 30 cents for each \$1 over \$12 000
\$30 001 – \$45 000	\$5400 plus 40 cents for each \$1 over \$30 000
\$45 001 – \$60 000	\$11 400 plus 50 cents for each \$1 over \$45 000
over \$60 000	\$18 900 plus 55 cents for each \$1 over \$60 000

Using the tax table, what is the tax payable on \$43 561?

- (A) \$5424.40
(B) \$10 824.40
(C) \$16 224.40
(D) \$17 424.40

- 7 Luke's normal rate of pay is \$15 per hour. Last week he was paid for 12 hours, at time-and-a-half.

How many hours would Luke need to work this week, at double time, to earn the same amount?

- (A) 4
(B) 6
(C) 8
(D) 9
- 8 What is the median of the following set of scores?

<i>Score</i>	<i>Frequency</i>
12	13
14	6
16	2
18	12
Total	33

- (A) 12
(B) 13
(C) 14
(D) 15
- 9 What is the value of $\sqrt{\frac{x+2y}{8y}}$ if $x = 5.6$ and $y = 3.1$, correct to 2 decimal places?
- (A) 0.69
(B) 2.62
(C) 2.83
(D) 4.77

- 10 The marks for a Science test and a Mathematics test are presented in box-and-whisker plots.

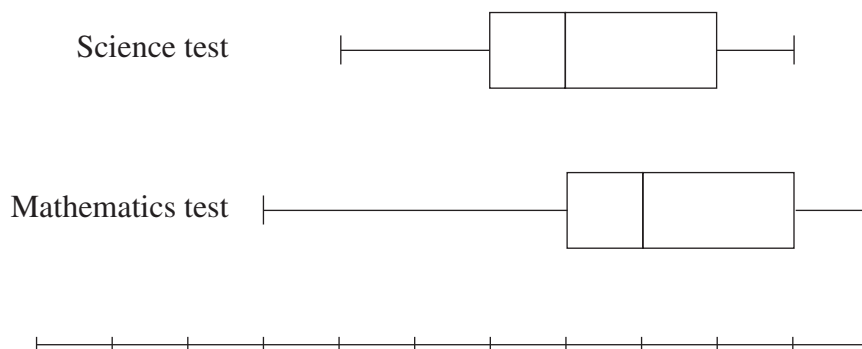

Which measure must be the same for both tests?

- (A) Mean
 - (B) Range
 - (C) Median
 - (D) Interquartile range
- 11 The diagram shows the floor of a shower. The drain in the floor is a circle with a diameter of 10 cm.

What is the area of the shower floor, excluding the drain?

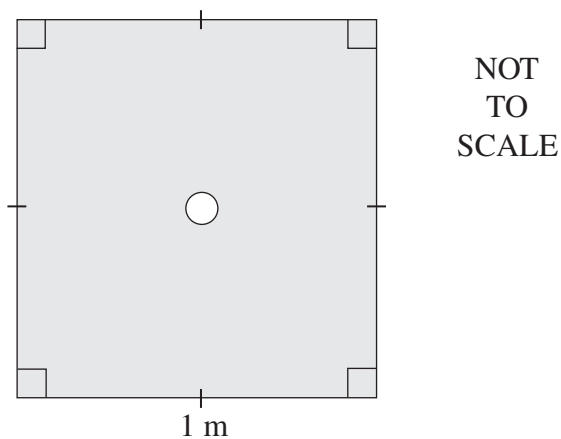

- (A) 9686 cm^2
- (B) 9921 cm^2
- (C) 9969 cm^2
- (D) $10\,000 \text{ cm}^2$

- 12 A scatterplot is shown.

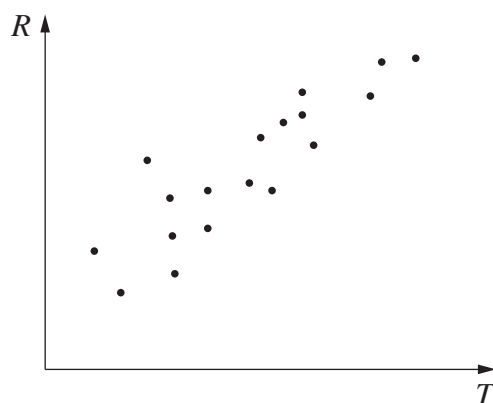

- Which of the following best describes the correlation between R and T ?
- (A) Positive
 - (B) Negative
 - (C) Positively skewed
 - (D) Negatively skewed
- 13 The height of each student in a class was measured and it was found that the mean height was 160 cm.
- Two students were absent. When their heights were included in the data for the class, the mean height did not change.
- Which of the following heights are possible for the two absent students?
- (A) 155 cm and 162 cm
 - (B) 152 cm and 167 cm
 - (C) 149 cm and 171 cm
 - (D) 143 cm and 178 cm

- 14 Danni is flying a kite that is attached to a string of length 80 metres. The string makes an angle of 55° with the horizontal.

How high, to the nearest metre, is the kite above Danni's hand?

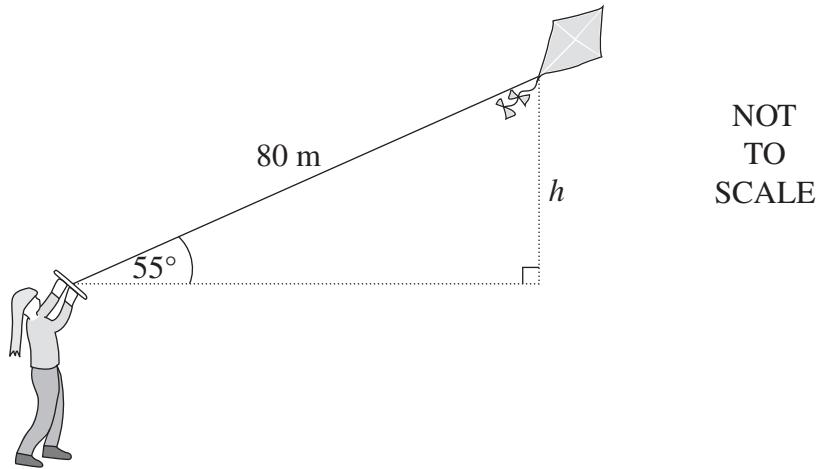

- (A) 46 m
(B) 66 m
(C) 98 m
(D) 114 m
- 15 Ali is buying a speedboat at Betty's Boats.

Betty's Boats

Cash price
\$16 000

OR

Terms
15% deposit plus
\$320 per month for
5 years

What is the amount of interest Ali will have to pay if he chooses to buy the boat on terms?

- (A) \$3200
(B) \$5600
(C) \$19 200
(D) \$21 600

- 16 A bag contains some marbles. The probability of selecting a blue marble at random from this bag is $\frac{3}{8}$.

Which of the following could describe the marbles that are in the bag?

- (A) 3 blue, 8 red
(B) 6 blue, 11 red
(C) 3 blue, 4 red, 4 green
(D) 6 blue, 5 red, 5 green
- 17 The diagram shows the position of Q , R and T relative to P .

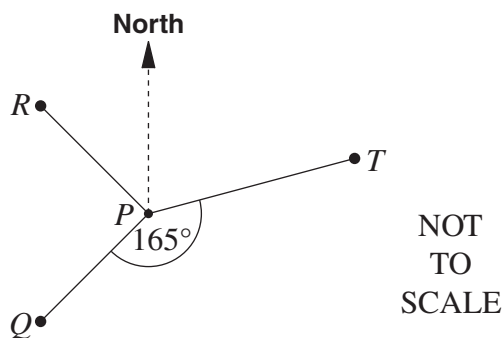

In the diagram,

Q is SW of P

R is NW of P

$\angle QPT$ is 165°

What is the bearing of T from P ?

- (A) 060°
(B) 075°
(C) 105°
(D) 120°
- 18 New car registration plates contain two letters followed by two numerals followed by two more letters eg AC 12 DC. Letters and numerals may be repeated.

Which of the following expressions gives the correct number of car registration plates that begin with the letter M?

- (A) $26^3 \times 10^2$
(B) $25^3 \times 10^2$
(C) $26^4 \times 10^2$
(D) $25^4 \times 10^2$

- 19 The height of a particular termite mound is directly proportional to the square root of the number of termites.

The height of this mound is 35 cm when the number of termites is 2000.

What is the height of this mound, in centimetres, when there are 10 000 termites?

- (A) 16
(B) 78
(C) 175
(D) 875
- 20 A point P lies between a tree, 2 metres high, and a tower, 8 metres high. P is 3 metres away from the base of the tree.

From P , the angles of elevation to the top of the tree and to the top of the tower are equal.

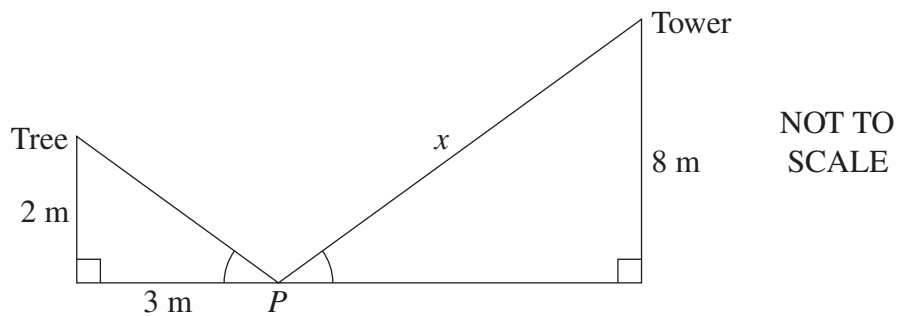

What is the distance, x , from P to the top of the tower?

- (A) 9 m
(B) 9.61 m
(C) 12.04 m
(D) 14.42 m

- 21** A sphere and a closed cylinder have the same radius.

The height of the cylinder is four times the radius.

What is the ratio of the volume of the cylinder to the volume of the sphere?

- (A) 2 : 1
- (B) 3 : 1
- (C) 4 : 1
- (D) 8 : 1

- 22** A die has faces numbered 1 to 6. The die is biased so that the number 6 will appear more often than each of the other numbers. The numbers 1 to 5 are equally likely to occur.

The die was rolled 1200 times and it was noted that the 6 appeared 450 times.

Which statement is correct?

- (A) The probability of rolling the number 5 is expected to be $\frac{1}{7}$.
- (B) The number 6 is expected to appear 2 times as often as any other number.
- (C) The number 6 is expected to appear 3 times as often as any other number.
- (D) The probability of rolling an even number is expected to be equal to the probability of rolling an odd number.

Section II

78 marks

Attempt Questions 23–28

Allow about 2 hours for this section

Answer each question in the appropriate writing booklet. Extra writing booklets are available.

All necessary working should be shown in every question.

Marks

Question 23 (13 marks) Use the Question 23 Writing Booklet.

- (a) You are organising an outside sporting event at Mathsville and have to decide which month has the best weather for your event. The average temperature must be between 20°C and 30°C , and average rainfall must be less than 80 mm.

The radar chart for Mathsville shows the average temperature for each month, and the table gives the average rainfall for each month.

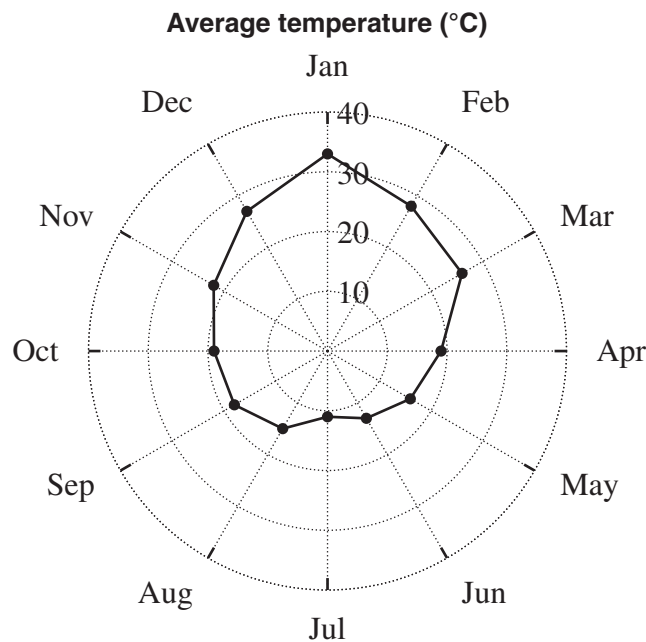

Average rainfall (mm)

	Jan	Feb	Mar	Apr	May	Jun	Jul	Aug	Sep	Oct	Nov	Dec
(mm)	150	162	86	95	104	140	59	81	60	72	70	90

- (i) If you consider only the temperature data, there are a number of possible months for holding the event. Name ONE of these months. 1
- (ii) If both rainfall and temperature data are considered, which month is the best month for the sporting event? 1

Question 23 continues on page 13

Question 23 (continued)

- (b) The capacity of a bottle is measured as 1.25 litres correct to the nearest 10 millilitres. 1

What is the percentage error for this measurement?

- (c) An alcoholic drink has 5.5% alcohol by volume. The label on a 375 mL bottle says it contains 1.6 standard drinks. 1
- (i) How many millilitres of alcohol are in a 375 mL bottle? 1
- (ii) It is recommended that a fully-licensed male driver should have a maximum of one standard drink every hour. 2

Express this as a rate in millilitres per minute, correct to one decimal place.

- (d) Solve $\frac{5x + 1}{2} = 4x - 7$. 3
- (e) In a survey, 450 people were asked about their favourite takeaway food. The results are displayed in the bar graph. 2

Takeaway food

Pizza	Hamburgers	Fish and chips
-------	------------	----------------

How many people chose pizza as their favourite takeaway food?

- (f) Christina has completed three Mathematics tests. Her mean mark is 72%. 2

What mark (out of 100) does she have to get in her next test to increase her mean mark to 73%?

End of Question 23

Question 24 (13 marks) Use the Question 24 Writing Booklet.

- (a) Bob is employed as a salesman. He is offered two methods of calculating his income.

Method 1: Commission only of 13% on all sales

Method 2: \$350 per week plus a commission of 4.5% on all sales

Bob's research determines that the average sales total per employee per month is \$15 670.

- (i) Based on his research, how much could Bob expect to earn in a year if he were to choose Method 1? **2**
- (ii) If Bob were to choose a method of payment based on the average sales figures, state which method he should choose in order to earn the greater income. Justify your answer with appropriate calculations. **3**
- (b) Three-digit numbers are formed from five cards labelled 1, 2, 3, 4 and 5.
- (i) How many different three-digit numbers can be formed? **1**
- (ii) If one of these numbers is selected at random, what is the probability that it is odd? **1**
- (iii) How many of these three-digit numbers are even? **1**
- (iv) What is the probability of randomly selecting a three-digit number less than 500 with its digits arranged in descending order? **2**
- (c) Heidi's funds in a superannuation scheme have a future value of \$740 000 in 20 years time. The interest rate is 4% per annum and earnings are calculated six-monthly. **3**

What single amount could be invested now to produce the same result over the same period of time at the same interest rate?

Question 25 (13 marks) Use the Question 25 Writing Booklet.

- (a) The number of penguins, P , after t years in a new colony can be found using the following formula.

$$P = a \times 2^t$$

- (i) If there are 24 penguins after two years, find the value of a . **2**
- (ii) How many years will it take for the number of penguins to first exceed 1500? **2**
- (b) In a drawer there are 30 ribbons. Twelve are blue and eighteen are red. Two ribbons are selected at random.

- (i) Copy and complete the probability tree diagram. **1**

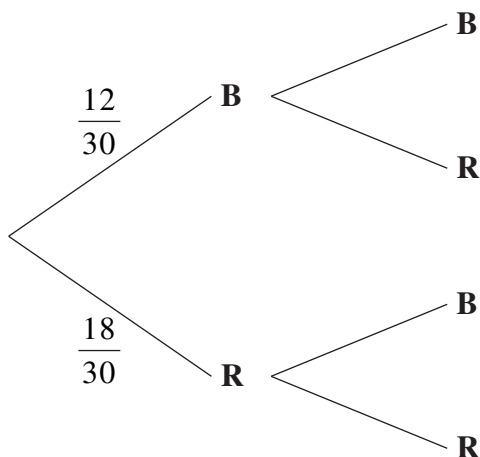

- (ii) What is the probability of selecting a pair of ribbons which are the same colour? **2**

Question 25 continues on page 16

Question 25 (continued)

(c) Pieces of cheese are cut from cylindrical blocks with dimensions as shown.

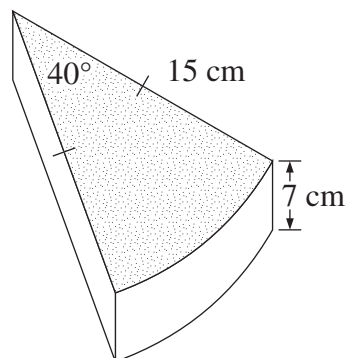

NOT
TO
SCALE

Twelve pieces are packed in a rectangular box. There are three rows with four pieces of cheese in each row. The curved surface is face down with the pieces touching as shown.

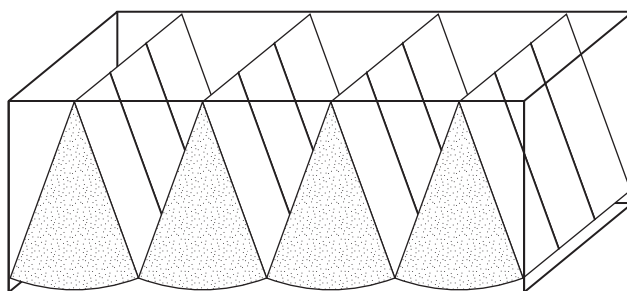

NOT
TO
SCALE

(i) What are the dimensions of the rectangular box?

4

To save packing space, the curved section is removed.

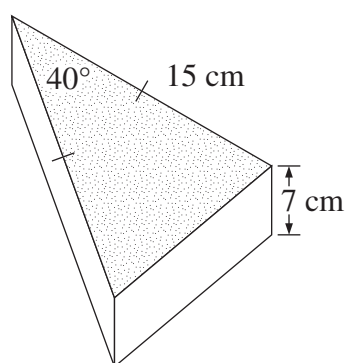

NOT
TO
SCALE

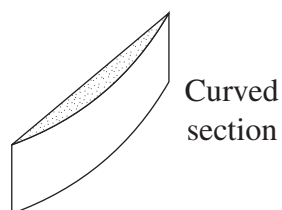

Curved
section

(ii) What is the volume of the remaining triangular prism of cheese?
Answer to the nearest cubic centimetre.

2

End of Question 25

Question 26 (13 marks) Use the Question 26 Writing Booklet.

- (a) Cecil invited 175 movie critics to preview his new movie. After seeing the movie, he conducted a survey. Cecil has almost completed the two-way table.

	<i>Aged <40</i>	<i>Aged ≥40</i>	<i>Totals</i>
Movie critics who liked the movie	65		102
Movie critics who did not like the movie		31	
<i>Totals</i>		(A)	175

- (i) Determine the value of (A). 1

- (ii) A movie critic is selected at random. 2

What is the probability that the critic was less than 40 years old and did not like the movie?

- (iii) Cecil believes that his movie will be a box office success if 65% of the critics who were surveyed liked the movie. 1

Will this movie be considered a box office success? Justify your answer.

- (b) The retirement ages of two million people are displayed in a table.

<i>Retirement age</i>	<i>Number of people (thousands)</i>
36–40	5
41–45	10
46–50	20
51–55	35
56–60	180
61–65	700
66–70	500
71–75	400
76–80	150

- (i) What is the relative frequency of the 51–55 year retirement age? 1

- (ii) Describe the distribution. 1

Question 26 continues on page 18

Question 26 (continued)

- (c) Joel is designing a game with four possible outcomes. He has decided on three of these outcomes. 2

	<i>Chance of occurring</i>	<i>Result</i>
Outcome 1	10%	Win \$12
Outcome 2	40%	Win \$6
Outcome 3	30%	Win \$3
Outcome 4		

What must be the value of the loss in Outcome 4 in order for the financial expectation of this game to be \$0?

- (d) The graph shows the predicted population age distribution in Australia in 2008.

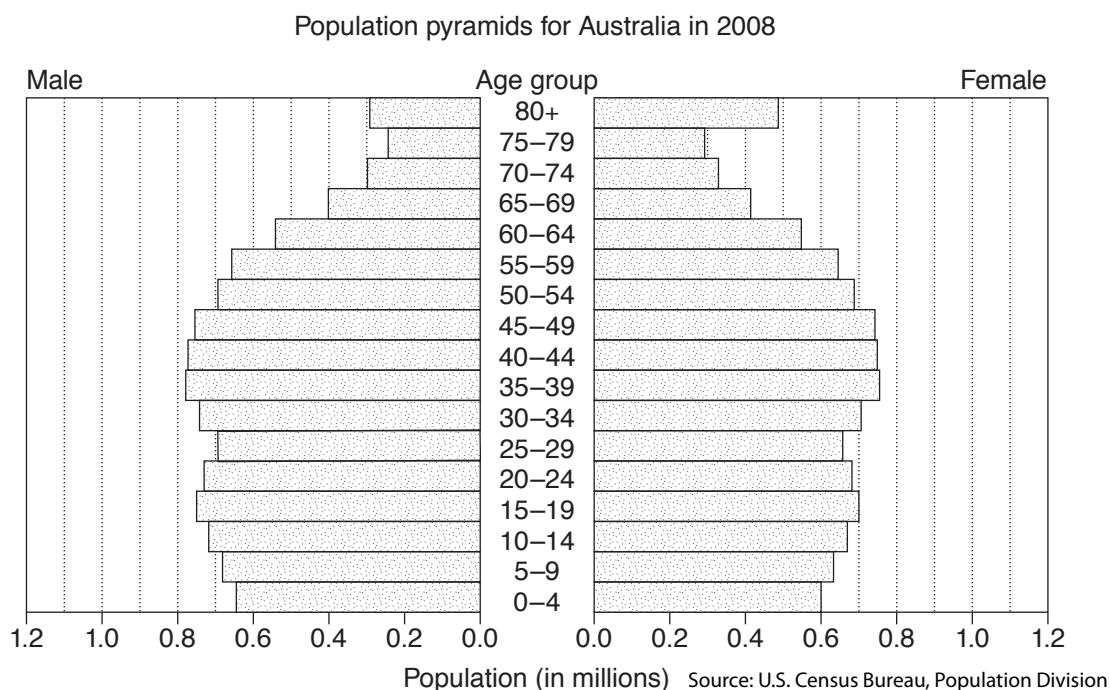

- (i) How many females are in the 0–4 age group? 1
- (ii) What is the modal age group? 1
- (iii) How many people are in the 15–19 age group? 2
- (iv) Give ONE reason why there are more people in the 80+ age group than in the 75–79 age group. 1

End of Question 26

Question 27 (13 marks) Use the Question 27 Writing Booklet.

- (a) An aircraft travels at an average speed of 913 km/h. It departs from a town in Kenya (0° , 38°E) on Tuesday at 10 pm and flies east to a town in Borneo (0° , 113°E).
- (i) What is the distance, to the nearest kilometre, between the two towns? (Assume the radius of Earth is 6400 km.) **2**
 - (ii) How long will the flight take? (Answer to the nearest hour.) **1**
 - (iii) What will be the local time in Borneo when the aircraft arrives? (Ignore time zones.) **2**
- (b) Julie takes out a \$290 000 home loan. The terms of the loan are 8.25% per annum over 30 years with monthly repayments.
- (i) Show that the minimum monthly repayment is \$2178.67, to the nearest cent. **2**
 - (ii) Determine the total amount paid for the loan over 30 years. **1**
 - (iii) Each month, Julie decides to pay \$250 more than the minimum monthly repayment. **3**
- Would she be able to pay off the loan in 20 years? Justify your answer by showing all calculations.
- (c) A plasma TV depreciated in value by 15% per annum. Two years after it was purchased it had depreciated to a value of \$2023, using the declining balance method. **2**

What was the purchase price of the plasma TV?

Question 28 (13 marks) Use the Question 28 Writing Booklet.

- (a) The following graph indicates z -scores of ‘height-for-age’ for girls aged 5–19 years.



- (i) What is the z -score for a six year old girl of height 120 cm? **1**
- (ii) Rachel is – years of age.
- (1) If 2.5% of girls of the same age are taller than Rachel, how tall is she? **1**
- (2) Rachel does not grow any taller. At age – , what percentage of girls of the same age will be taller than Rachel? **2**
- (iii) What is the average height of an 18 year old girl? **1**

Question 28 continues on page 21

Question 28 (continued)

- (iv) For adults (18 years and older), the Body Mass Index is given by **2**

$$B = \frac{m}{h^2}$$

where m = mass in kilograms and h = height in metres.

The medically accepted healthy range for B is $21 \leq B \leq 25$.

What is the minimum weight for an 18 year old girl of average height to be considered healthy?

- (v) The average height, C , in centimetres, of a girl between the ages of 6 years and 11 years can be represented by a line with equation

$$C = 6A + 79$$

where A is the age in years.

- (1) For this line, the gradient is 6. **1**

What does this indicate about the heights of girls aged 6 to 11?

- (2) Give ONE reason why this equation is not suitable for predicting heights of girls older than 12. **1**

- (b) A tunnel is excavated with a cross-section as shown.

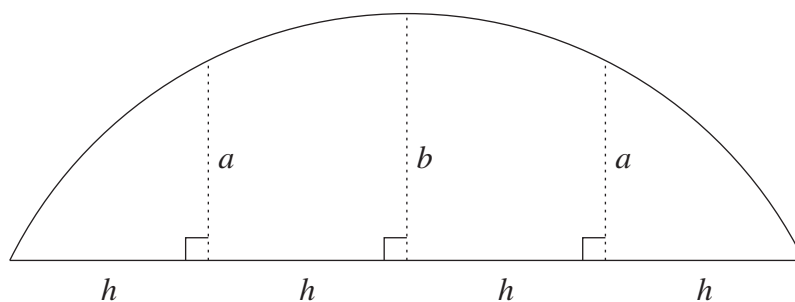

- (i) Find an expression for the area of the cross-section using TWO applications of Simpson's rule. **2**

- (ii) The area of the cross-section must be 600 m^2 . The tunnel is 80 m wide. **2**

If the value of a increases by 2 m, by how much will b change?

End of paper

BLANK PAGE

BLANK PAGE

BLANK PAGE

FORMULAE SHEET

Area of an annulus

$$A = \pi(R^2 - r^2)$$

R = radius of outer circle

r = radius of inner circle

Area of an ellipse

$$A = \pi ab$$

a = length of semi-major axis

b = length of semi-minor axis

Area of a sector

$$A = \frac{\theta}{360} \pi r^2$$

θ = number of degrees in central angle

Arc length of a circle

$$l = \frac{\theta}{360} 2\pi r$$

θ = number of degrees in central angle

Simpson's rule for area approximation

$$A \approx \frac{h}{3} (d_f + 4d_m + d_l)$$

h = distance between successive measurements

d_f = first measurement

d_m = middle measurement

d_l = last measurement

Surface area

Sphere $A = 4\pi r^2$

Closed cylinder $A = 2\pi rh + 2\pi r^2$

r = radius

h = perpendicular height

Volume

Cone $V = \frac{1}{3} \pi r^2 h$

Cylinder $V = \pi r^2 h$

Pyramid $V = \frac{1}{3} Ah$

Sphere $V = \frac{4}{3} \pi r^3$

r = radius

h = perpendicular height

A = area of base

Sine rule

$$\frac{a}{\sin A} = \frac{b}{\sin B} = \frac{c}{\sin C}$$

Area of a triangle

$$A = \frac{1}{2} ab \sin C$$

Cosine rule

$$c^2 = a^2 + b^2 - 2ab \cos C$$

or

$$\cos C = \frac{a^2 + b^2 - c^2}{2ab}$$

FORMULAE SHEET

Simple interest

$$I = Prn$$

P = initial quantity

r = percentage interest rate per period,
expressed as a decimal

n = number of periods

Compound interest

$$A = P(1+r)^n$$

A = final balance

P = initial quantity

n = number of compounding periods

r = percentage interest rate per compounding
period, expressed as a decimal

Future value (A) of an annuity

$$A = M \left\{ \frac{(1+r)^n - 1}{r} \right\}$$

M = contribution per period,
paid at the end of the period

Present value (N) of an annuity

$$N = M \left\{ \frac{(1+r)^n - 1}{r(1+r)^n} \right\}$$

or

$$N = \frac{A}{(1+r)^n}$$

Straight-line formula for depreciation

$$S = V_0 - Dn$$

S = salvage value of asset after n periods

V_0 = purchase price of the asset

D = amount of depreciation apportioned
per period

n = number of periods

Declining balance formula for depreciation

$$S = V_0(1-r)^n$$

S = salvage value of asset after n periods

r = percentage interest rate per period,
expressed as a decimal

Mean of a sample

$$\bar{x} = \frac{\sum x}{n}$$

$$\bar{x} = \frac{\sum fx}{\sum f}$$

\bar{x} = mean

x = individual score

n = number of scores

f = frequency

Formula for a z -score

$$z = \frac{x - \bar{x}}{s}$$

s = standard deviation

Gradient of a straight line

$$m = \frac{\text{vertical change in position}}{\text{horizontal change in position}}$$

Gradient-inte cept form of a straight line

$$y = mx + b$$

m = gradient

b = y -intercept

Probability of an event

The probability of an event where outcomes
are equally likely is given by:

$$P(\text{event}) = \frac{\text{number of favourable outcomes}}{\text{total number of outcomes}}$$