

**B O A R D O F S T U D I E S**  
NEW SOUTH WALES

**2006**

**HIGHER SCHOOL CERTIFICATE  
EXAMINATION**

# Engineering Studies

## General Instructions

- Reading time – 5 minutes
- Working time – 3 hours
- Write using black or blue pen
- Draw diagrams using pencil
- Board-approved calculators may be used
- A formulae sheet is provided at the back of this paper
- Write your Centre Number and Student Number at the top of pages 9, 11, 15, 19, 23, 27, 31 and 33

## Total marks – 100

**Section I** Pages 2–7

### 10 marks

- Attempt Questions 1–10
- Allow about 20 minutes for this section

**Section II** Pages 9–29

### 70 marks

- Attempt Questions 11–16
- Allow about 2 hours for this section

**Section III** Pages 31–34

### 20 marks

- Attempt Questions 17–18
- Allow about 40 minutes for this section

## Section I

10 marks

Attempt Questions 1–10

Allow about 20 minutes for this section

Use the multiple-choice answer sheet.

Select the alternative A, B, C or D that best answers the question. Fill in the response oval completely.

**Sample:**  $2 + 4 =$  (A) 2 (B) 6 (C) 8 (D) 9  
A  B  C  D

If you think you have made a mistake, put a cross through the incorrect answer and fill in the new answer.

A  B  C  D

If you change your mind and have crossed out what you consider to be the correct answer, then indicate the correct answer by writing the word *correct* and drawing an arrow as follows.

A  B  C  D   
*correct* ↙

---

- 1 A steel sample is subjected to a tensile test and the following graph is generated.

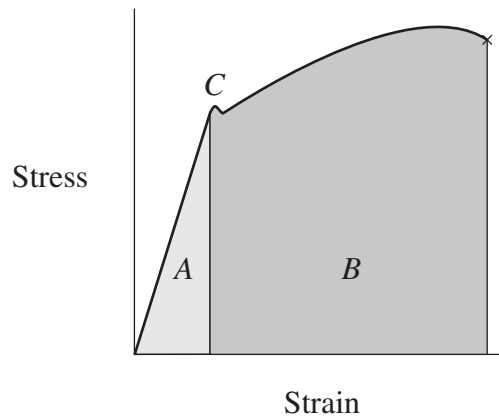

What is the best indication of the sample's resilience?

- (A) Area *A*
  - (B) Area *B*
  - (C) Areas *A* and *B*
  - (D) Point *C*
- 2 In a diesel-electric locomotive, the mechanical energy of the diesel engine is converted into electrical energy to drive the traction system.
- Which configuration describes the machines in the locomotive's power train?
- (A) Generator driving generator driving motor
  - (B) Generator driving motor driving generator
  - (C) Motor driving generator driving motor
  - (D) Motor driving motor driving generator
- 3 What is the most appropriate process for the manufacture of steel rails for use in railway track?
- (A) Casting
  - (B) Extrusion
  - (C) Forging
  - (D) Rolling

4 How many edges (lines) in the views below are shown as true length?

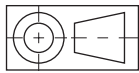
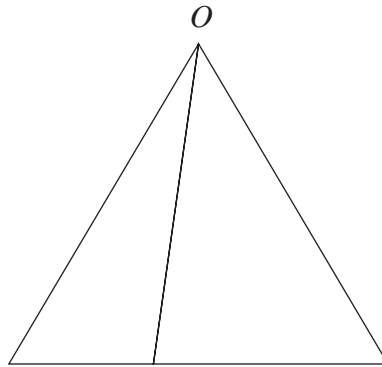
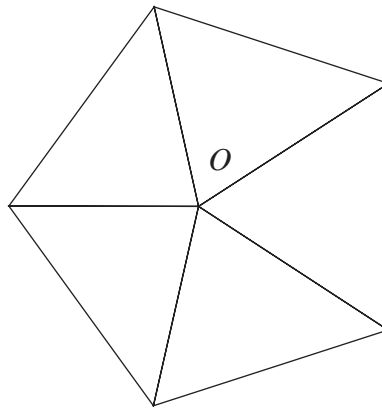

- (A) 0
- (B) 1
- (C) 5
- (D) 6

- 5 Two identical boxes are resting on a truck tray. The tray is gradually tilted. The load in one box is twice as heavy as the load in the other box.

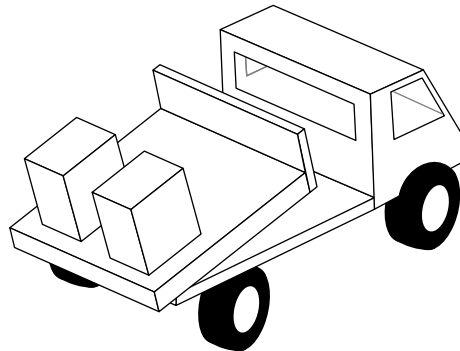

Which statement is true?

- (A) The lightly loaded box would slide before the heavily loaded box.
  - (B) The heavily loaded box would slide before the lightly loaded box.
  - (C) Both boxes would slide at the same time regardless of their load.
  - (D) Both boxes would have the same normal reaction regardless of their load.
- 6 What is an advantage of ceramic insulators compared with polymer insulators for use on transmission towers?
- (A) Ceramic insulators are not as heavy.
  - (B) Ceramic insulators are not affected by UV radiation.
  - (C) Ceramic insulators are more likely to creep under load.
  - (D) Ceramic insulators are able to be formed into more appropriate shapes.

- 7 A steel tube and a steel round bar have the same cross-sectional area.

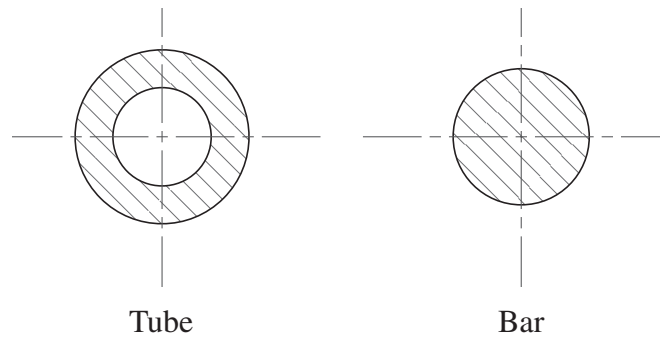

Which statement is true?

- (A) The tube is lighter per metre.
  - (B) The bar has greater tensile strength.
  - (C) The tube has greater resistance to bending due to its greater depth of section.
  - (D) The bar is stiffer because it has more material around the neutral axis.
- 8 Which defect sometimes occurs in sand casting?
- (A) Gas porosity
  - (B) Excess nitriding
  - (C) Induced magnetisation
  - (D) Gauge thickness inconsistencies
- 9 What is a fuse in an electrical circuit designed to do?
- (A) Create an open circuit if the circuit current is too large
  - (B) Create a short circuit if the circuit current is too large
  - (C) Create an open circuit if the circuit voltage is too large
  - (D) Create a short circuit if the circuit voltage is too large

- 10 A shop awning has end  $A$  built into the wall and is supported by a cable from anchor point  $C$  to attachment point  $B$ .

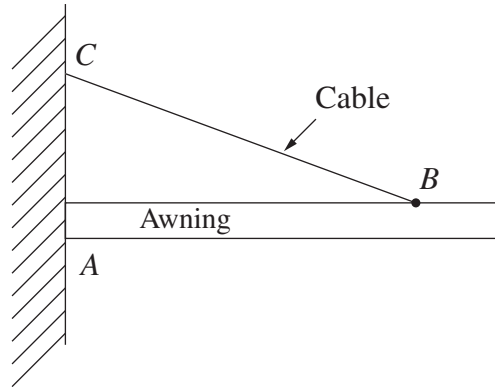

Which diagram represents the complete free-body diagram of the forces acting on the awning?

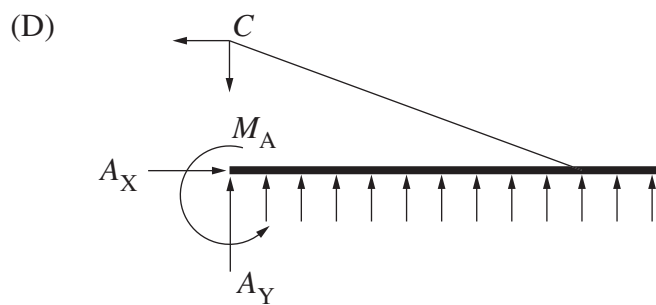
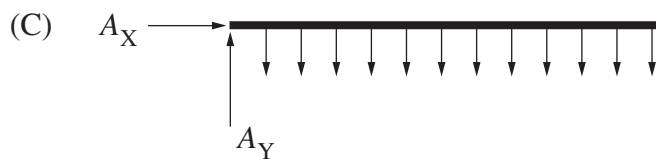
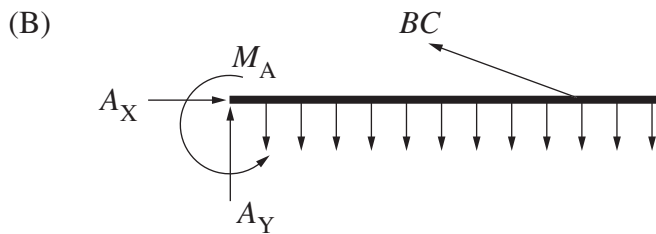
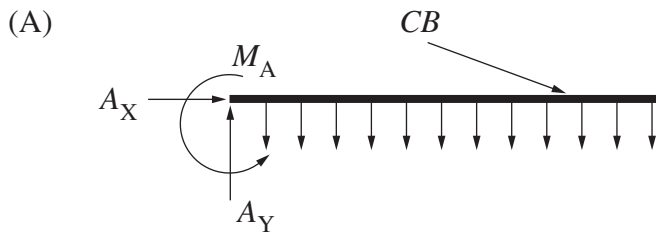

BLANK PAGE

Engineering Studies

--	--	--	--	--

Centre Number

Section II

--	--	--	--	--	--	--	--	--

Student Number

70 marks

Attempt Questions 11–16

Allow about 2 hours for this section

Answer the questions in the spaces provided.

Marks

**Question 11 — Historical and Societal Influences, and the Scope of the Profession (10 marks)**

(a) Describe how engineers ensure a high standard of safety at: **3**

- the design stage;

.....

.....

.....

- the construction/manufacturing stage; and

.....

.....

.....

- during the service life.

.....

.....

.....

**Question 11 continues on page 10**

Question 11 (continued)

- (b) Engineers respond to the needs of the community in which they work.
  - (i) Identify an issue faced by society during the last 100 years that was resolved by engineers. Describe the solution that was achieved. 2  
.....  
.....  
.....  
.....  
.....
  - (ii) Identify an ethical issue that engineers may need to resolve. Describe a strategy adopted by engineers to address this ethical issue. 2  
.....  
.....  
.....  
.....  
.....
- (c) Explain, providing TWO examples, how the recycling of materials is being incorporated into engineering design. 3  
.....  
.....  
.....  
.....  
.....  
.....  
.....  
.....  
.....

**End of Question 11**

--	--	--	--	--

Centre Number

Section II (continued)

--	--	--	--	--	--	--	--	--	--

Student Number

Marks

Question 12 — Civil Structures (10 marks)

Use the diagram below to answer parts (a) to (c).

An enclosed walkway truss connects a carpark to a building as shown below. The walkway is fabricated from hollow steel sections.

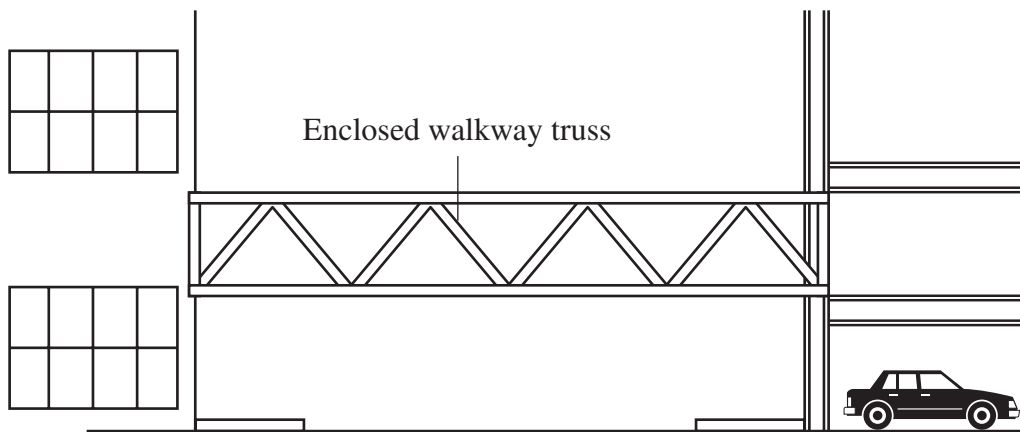

- (a) (i) What are FOUR sources of applied loads that structural engineers considered when designing the truss? 2

.....

.....

.....

.....

- (ii) Hollow steel sections are cold-formed. 1

List TWO changes that occur in the properties of steel as a result of cold-forming.

.....

.....

Question 12 continues on page 12

Question 12 (continued)

(b) Typical loads on the truss walkway are shown below.

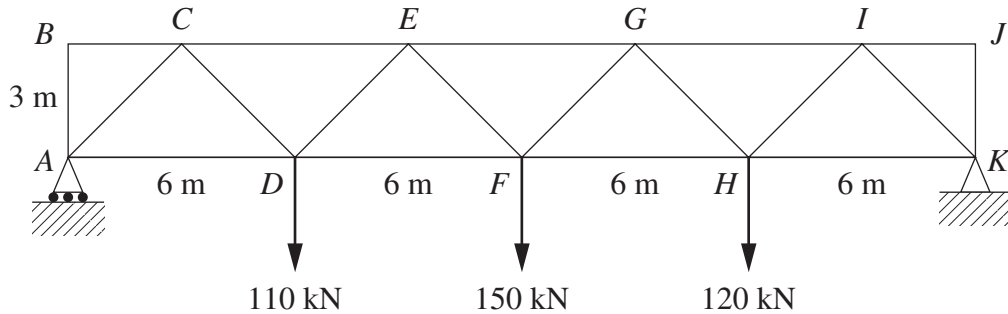

(i) If there is a roller support at *A* and a pin support at *K*, calculate the magnitude and direction of the reactions at *A* and *K*. 2

*A* = ..... kN

*K* = ..... kN

(ii) Calculate the magnitude and nature of the force in member *GI*. 2

Magnitude of force: ..... kN

Nature of force: .....

Question 12 continues on page 13

Question 12 (continued)

(c) Justify the selection of a truss for the structure of the walkway.

**3**

.....

.....

.....

.....

.....

.....

.....

.....

**End of Question 12**

BLANK PAGE

--	--	--	--	--

Centre Number

Section II (continued)

--	--	--	--	--	--	--	--	--	--

Student Number

Marks

**Question 13 — Personal and Public Transport (10 marks)**

- (a) Mild steel tow pins are used to couple aircraft to tractor tugs. The pins are bending under service load. It has been recommended that the problem be fixed by using medium-carbon steel in the replacement pins. **2**

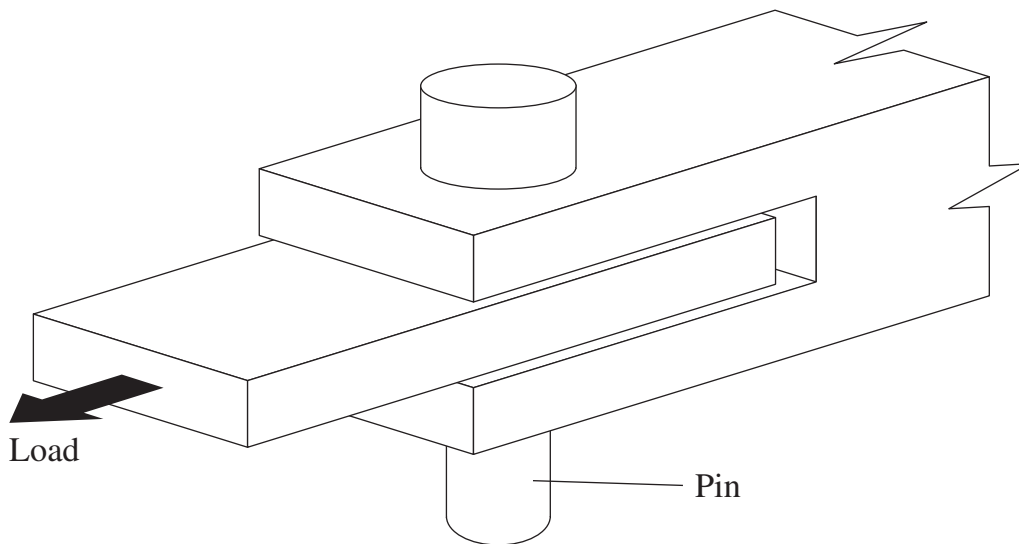

Describe a heat treatment process that would be applied to the replacement medium-carbon steel pins to improve their resistance to bending.

.....

.....

.....

.....

**Question 13 continues on page 16**

Question 13 (continued)

- (b) (i) How does vulcanisation (the addition of sulfur) change the structure of natural rubber? **1**

.....  
.....

- (ii) Modern truck and car tyres are a composite of several materials. Suitable materials are combined with the vulcanised rubber to improve tyre performance. **2**

Name a suitable material, and justify its inclusion in the composite.

.....  
.....  
.....  
.....

- (c) Twenty-five 40 kg boxes are raised 6 m by a conveyor belt onto an aircraft. This task is completed in 4 minutes. **3**

Calculate the average power required.

Average power = ..... W

**Question 13 continues on page 17**

Question 13 (continued)

- (d) A conveyor system has a mechanical efficiency of 85%, and is driven by a DC motor with an efficiency of 60%. **2**

How much power must be supplied to the motor to enable the conveyor to produce 2 kW of mechanical lift?

Power = ..... kW

**End of Question 13**

BLANK PAGE

Engineering Studies

--	--	--	--	--

Centre Number

Section II (continued)

--	--	--	--	--	--	--	--	--

Student Number

---

Question 14 — Lifting Devices (10 marks)

Please turn over

**Question 14 — Lifting Devices (10 marks)**

- (a) A mechanical jack is constructed with pin-jointed struts and a threaded rod (screw). In the position shown, the axial force in the threaded rod is 7 kN.

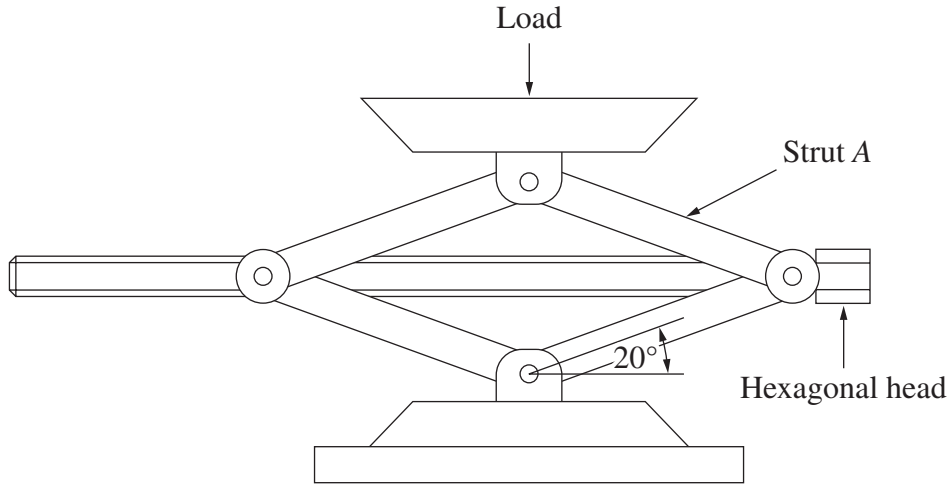

- (i) If the effective area of the threaded rod is  $175 \text{ mm}^2$ , calculate the magnitude of the stress. 2

Magnitude of the stress = ..... MPa

- (ii) Determine the magnitude of the force in strut A. 2

Force = ..... kN

**Question 14 continues on page 21**

Question 14 (continued)

(b) A hydraulic jack is shown.

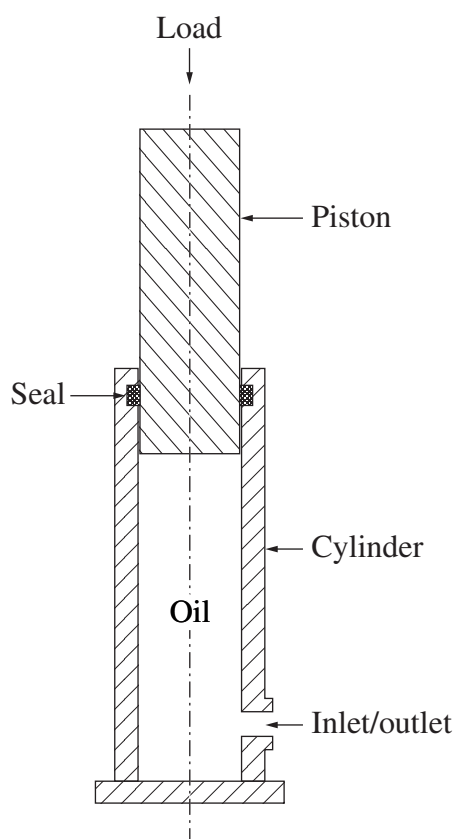

- (i) The cross-sectional area of the piston is  $5000 \text{ mm}^2$ , and the maximum allowable oil pressure is 20 MPa. 2

If a factor of safety of 2 is applicable for this system, calculate the maximum allowable load (kg) on the piston.

Maximum allowable load = ..... kg

**Question 14 continues on page 22**

Question 14 (continued)

- (ii) The oil in the cylinder is retained by a seal fitted between the cylinder and the piston. 2

Identify an important property that the material for this seal must possess, and name an appropriate material for the seal.

.....  
.....  
.....

- (c) The mechanical jack in part (a) is operated by a handle (shown below) that connects to the hexagonal head. 2

Identify an appropriate manufacturing technique for the steel socket of this handle. Justify this manufacturing technique.



.....  
.....  
.....  
.....  
.....  
.....  
.....  
.....

**End of Question 14**

--	--	--	--	--

Centre Number

Section II (continued)

--	--	--	--	--	--	--	--	--	--

Student Number

**Marks**

**Question 15 — Aeronautical Engineering (15 marks)**

(a) Ailerons are fitted to the rear section of an aircraft's main wing.

**3**

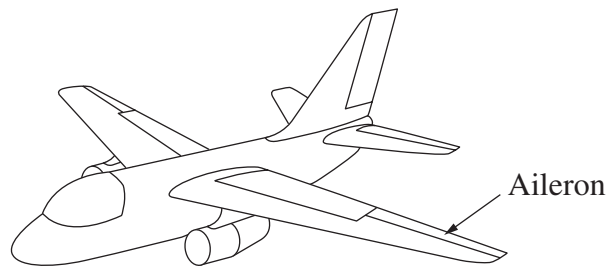

Explain, in terms of airflow, how ailerons can be used to control an aircraft.

.....

.....

.....

.....

.....

**Question 15 continues on page 24**

Question 15 (continued)

Parts (b) and (c) refer to the stub-axle assembly for a landing wheel on a light aircraft.

**Stub-axle assembly**

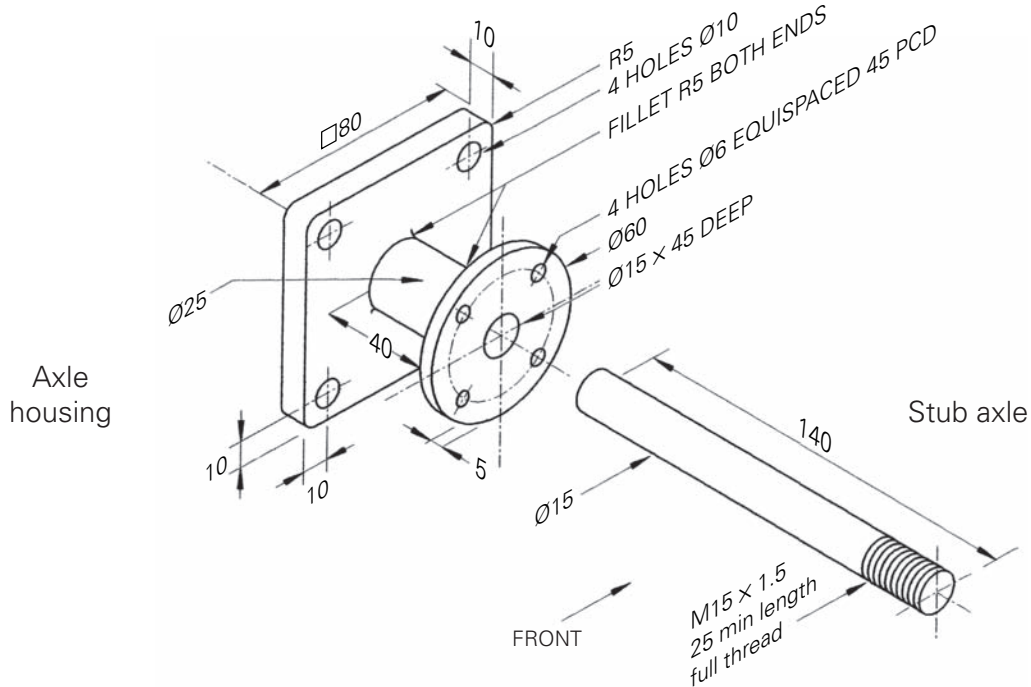

- (b) (i) Describe a suitable method of testing to ensure that each stub-axle is free of internal defects before it enters service. 2

.....

.....

.....

.....

- (ii) List TWO defects that might be found during a routine inspection of the stub-axle assembly after 2000 take-off and landing cycles. 2

.....

.....

.....

.....

- (c) On the grid provided on page 25, complete a full size orthogonal sketch of the assembled stub-axle. Draw a half-section front view and a right-side view, as indicated. Apply AS1100 drawing standards. Do NOT dimension. 5

**Question 15 continues on page 25**

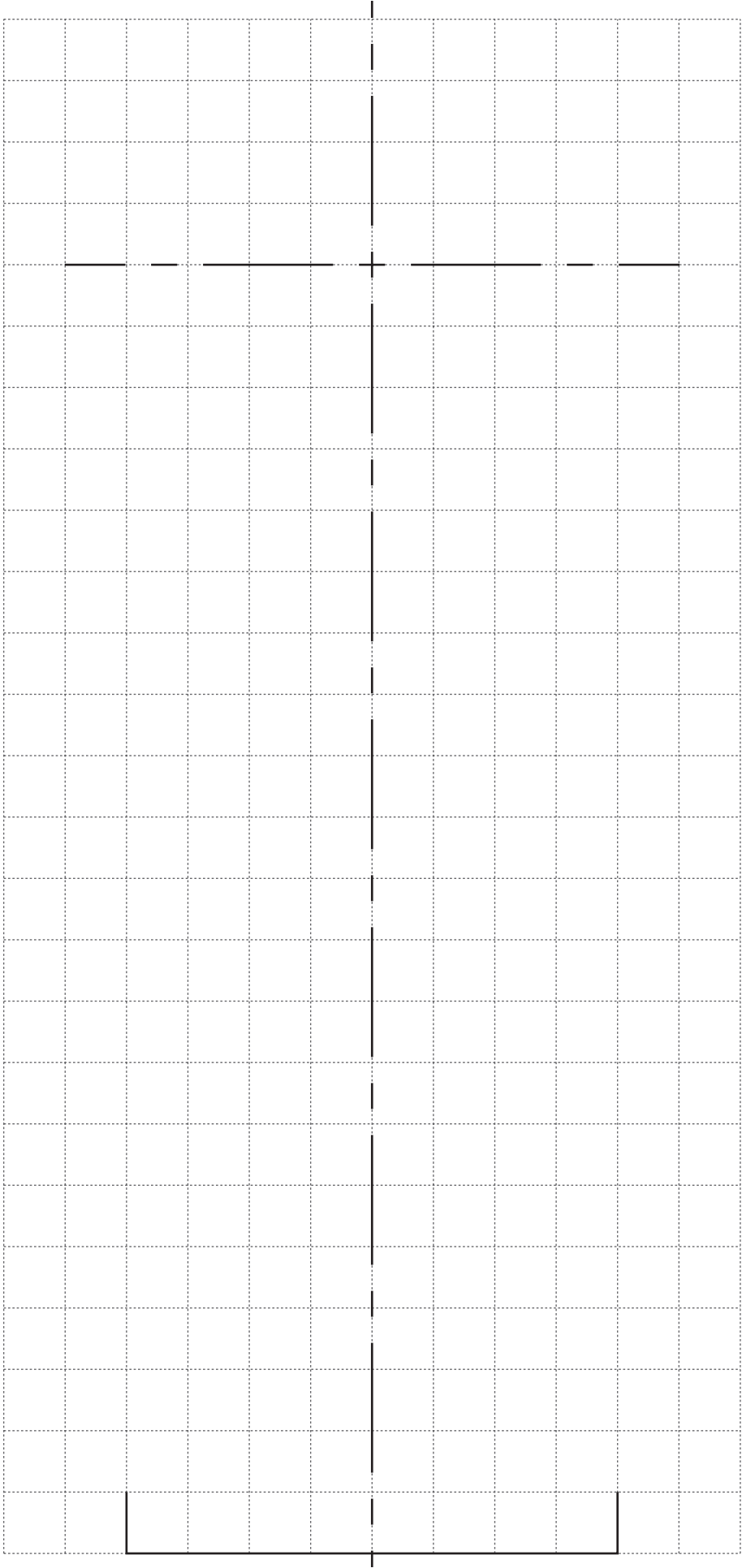

RIGHT SIDE VIEW

HALF-SECTION FRONT VIEW

Question 15 continues on page 26

Question 15 (continued)

(d) An aircraft has a mass of 1200 kg and experiences a drag of 3 kN.

3

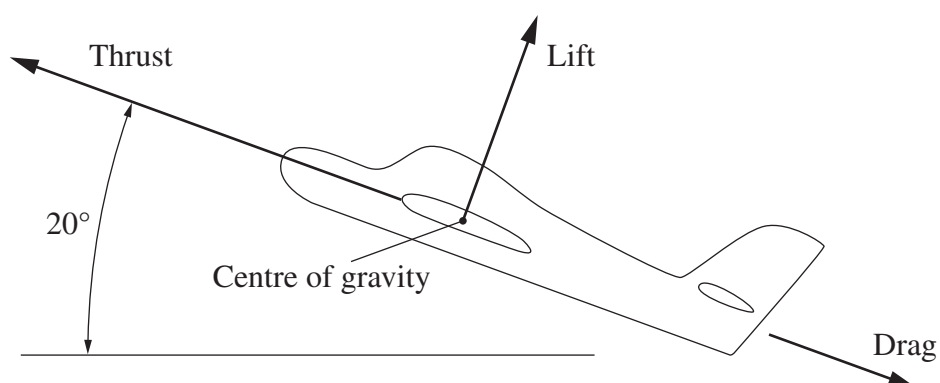

Determine the magnitude of the thrust required to maintain this aircraft in a climb of 20° at constant speed.

Magnitude of thrust = .....

**End of Question 15**

--	--	--	--	--

Centre Number

Section II (continued)

--	--	--	--	--	--	--	--	--	--

Student Number

Marks

Question 16 — Telecommunication (15 marks)

(a) The table below shows bands of the electromagnetic spectrum.

<i>Common description</i>	<i>Carrier wavelength</i>	<i>Carrier frequency range</i>
Low frequency (LF)	$10^4 \text{ m} - 10^3 \text{ m}$	30–300 kHz
Medium frequency (MF)	$10^3 \text{ m} - 10^2 \text{ m}$	300–3000 kHz
High frequency (HF)	100 m–10 m	3–30 MHz
Very high frequency (VHF)	10 m–1 m	30–300 MHz
Ultra high frequency (UHF)	1 m–100 mm	300–3000 MHz

Air traffic controllers talk with pilots in the air using the high frequency (HF) band for radio communications.

- (i) Referring to antenna length, explain why HF radio signals are preferred over LOWER frequency signals for long-distance communication. 2

.....

.....

.....

.....

.....

- (ii) Referring to radio wave propagation, explain why HF radio signals are preferred over HIGHER frequency signals for long-distance communication. 2

.....

.....

.....

.....

.....

Question 16 continues on page 28

Question 16 (continued)

(b) Air traffic control systems use both modulated and unmodulated signals.

(i) Explain the purpose of modulation.

3

.....  
.....  
.....  
.....  
.....  
.....

(ii) Air traffic control radar transmits a radio beam, and searches for reflections from airborne aircraft.

2

Explain why modulation is not essential for a radar transmission.

.....  
.....  
.....  
.....

(c) Radar signals can be up to 1 megawatt in transmitted power.

2

Describe TWO strategies that will reduce the potential danger to staff and public from radar transmission.

.....  
.....  
.....  
.....  
.....

Question 16 continues on page 29

Question 16 (continued)

- (d) The orthogonal assembly drawing below shows the details of a push switch. 4

On the centre axis provided, sketch a pictorial drawing of the push switch, showing three faces of the hexagonal prism. Do NOT include any hidden detail in your sketch.

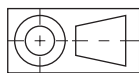
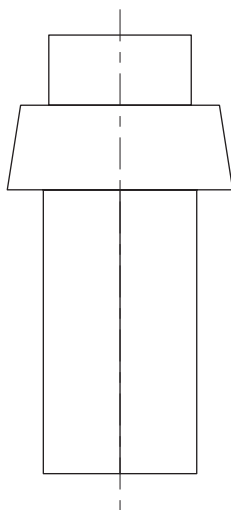
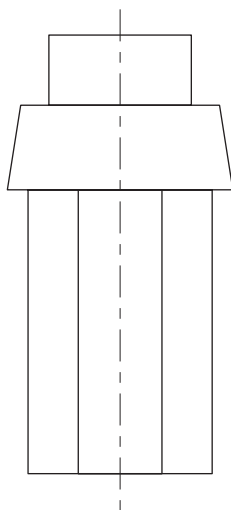
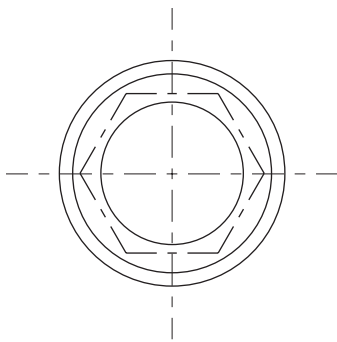

Centre axis

End of Question 16

BLANK PAGE

--	--	--	--	--

Centre Number

Section III

--	--	--	--	--	--	--	--	--

Student Number

20 marks

Attempt Questions 17–18

Allow about 40 minutes for this section

Answer the questions in the spaces provided.

Marks

Question 17 — Engineering and the Engineering Report (10 marks)

The playground equipment in the diagram consists of a beam pinned between two posts, centred 3 metres apart.

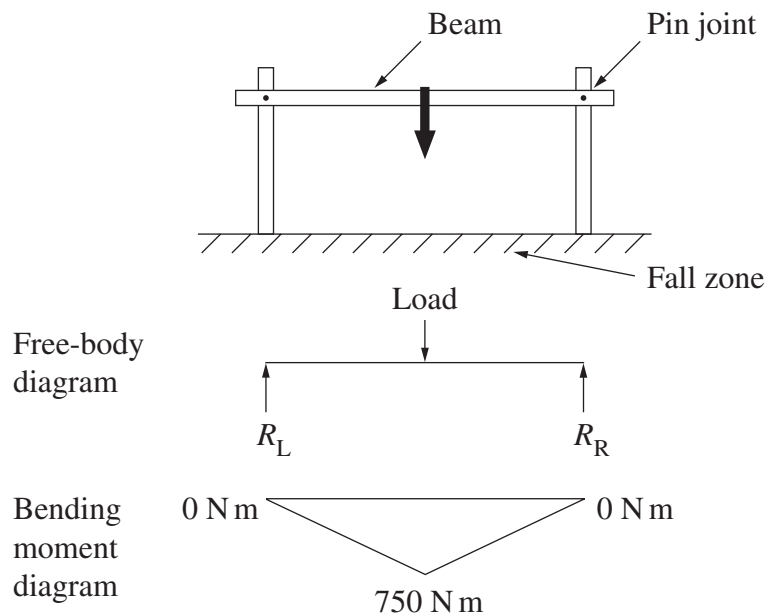

- (a) Calculate the magnitude of the reactions  $R_L$  and  $R_R$ , and determine the load being applied at the centre of the beam. 3

$R_R = \dots\dots\dots \text{ N}$

$R_L = \dots\dots\dots \text{ N}$

Load =  $\dots\dots\dots \text{ kg}$

Question 17 continues on page 32

Question 17 (continued)

- (b) (i) Parts of the playground equipment are made of galvanised steel. 1

Why is galvanising effective?

.....  
.....

- (ii) List FOUR service properties of the fall zone material underneath the equipment. 2

.....  
.....  
.....  
.....

- (c) An engineer is writing a report about playground equipment. The following sections would be included: 4

- introduction to the report
- analysis of the issues
- recommendations
- references.

Describe the purpose of each of these sections.

.....  
.....  
.....  
.....  
.....  
.....  
.....  
.....  
.....  
.....

**End of Question 17**

--	--	--	--	--

Centre Number

Section III (continued)

--	--	--	--	--	--	--	--	--

Student Number

Marks

Question 18 — Engineering and the Engineering Report (10 marks)

A hybrid vehicle has the following components:

- petrol internal combustion engine
- fuel tank
- electric motor/generator
- batteries.

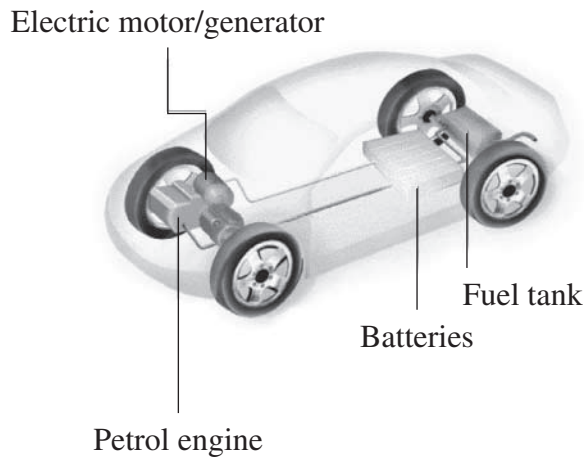

- (a) Suggest how integrated systems in a hybrid vehicle may achieve improved energy efficiency compared with conventional petrol vehicles. 3

.....

.....

.....

.....

.....

.....

Question 18 continues on page 34

Question 18 (continued)

- (b) The design engineers recommended that the fuel tank for the hybrid vehicle be manufactured from high density polyethylene. 2

Explain TWO criteria that may have led the engineers to recommend this material for the hybrid vehicle.

.....

.....

.....

.....

.....

- (c) Motors can be evaluated on criteria such as size and performance. 3

Outline how an engineer may use this type of information to make a recommendation on the 'best' motor for the 'hybrid' vehicle.

.....

.....

.....

.....

.....

.....

.....

- (d) Design engineers frequently use computer assisted drawing (CAD) in their work. 2

List TWO advantages of CAD, other than reduced drawing time.

.....

.....

.....

.....

**End of paper**

2006 HIGHER SCHOOL CERTIFICATE EXAMINATION  
Engineering Studies

---

**FORMULAE SHEET**

**Force, Moments**

$$F = ma; \quad M = Fd$$

If a body is in equilibrium, then  $\sum F_x = 0; \quad \sum F_y = 0; \quad \sum M = 0$

**Friction**

$$F = \mu N; \quad \mu = \tan \phi$$

**Energy, Work, Power**

$$KE = \frac{1}{2}mv^2; \quad PE = mgh; \quad W = Fs = \Delta PE + \Delta KE; \quad P = \frac{W}{t}$$

**Pressure**

$$P = \frac{F}{A}; \quad P = P_o + \rho gh$$

**Stress and Strain**

$$\sigma = \frac{F}{A}; \quad \epsilon = \frac{e}{L}; \quad E = \frac{\sigma}{\epsilon}; \quad \sigma = \frac{My}{I}$$

$$\sigma_{\text{allowable}} = \frac{\sigma_{\text{yield}}}{F \text{ of } S} \text{ (Ductile);} \quad \sigma_{\text{allowable}} = \frac{\sigma_{\text{UTS}}}{F \text{ of } S} \text{ (Brittle)}$$

**Machines**

$$MA = \frac{L}{E}; \quad VR = \frac{d_E}{d_L}; \quad \eta = \frac{MA}{VR}$$

BLANK PAGE